

# TREK

OWNER'S MANUAL

# YOUR TREK BICYCLE

- (A) Saddle
- (B) Seatpost
- (C) Rear brake
- (D) Freewheel
- (E) Rear derailleur
- (F) Chain
- (G) Front derailleur
- (H) Crankset
- (I) Pedal
- (J) Toeclip
- (K) Stem
- (L) Handlebars
- (M) Brake lever
- (N) Shift levers
- (O) Front brake
- (P) Tire
- (Q) Rim
- (R) Hub
- (S) Valve stem
- (T) Reflector

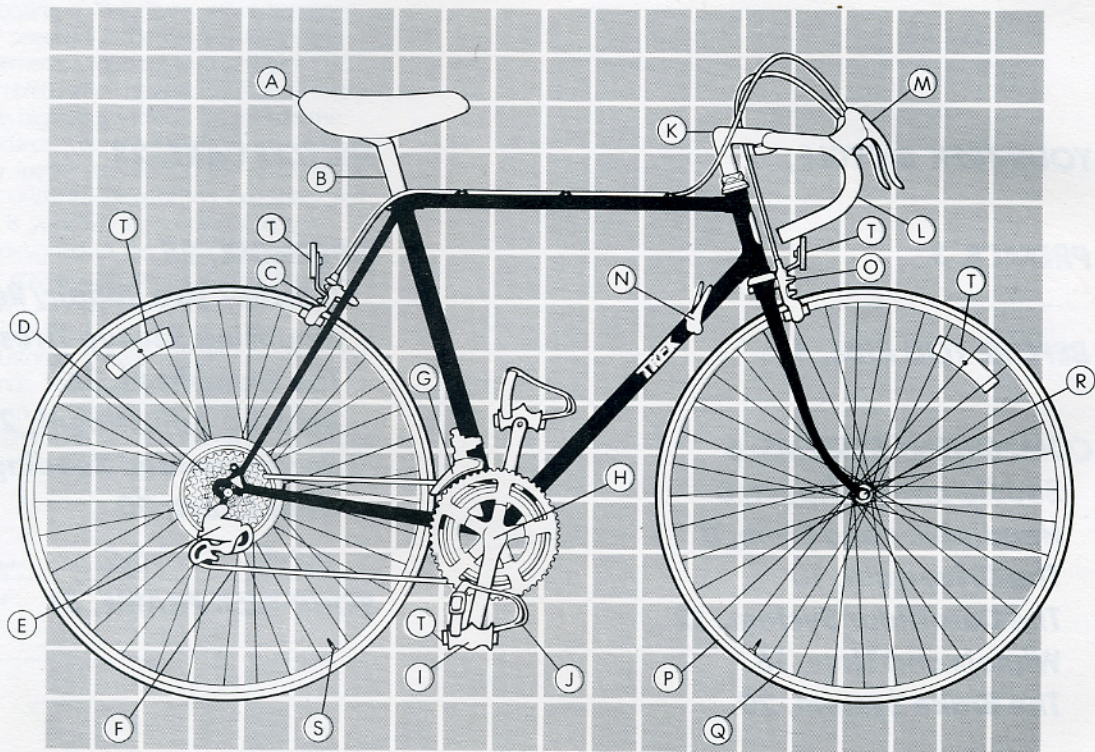

# **CONTENTS**

**YOUR TREK BICYCLE, 1**

**PREFACE, 3**

**BEFORE YOU RIDE, 4**

**COMPONENT SYSTEMS, 6**

**Saddle and Seatpost, 6**

**Handlebars and Stem, 8**

**The Drivetrain, 10**

**The Derailleur System, 12**

**Wheels and Tires, 16**

**The Brake System, 20**

**BICYCLE CARE, 23**

**APPENDIX, 25**

**Clincher Tire Repair/Replacement, 25**

**Mounting Sew-up Tires, 25**

**The Freewheel, 26**

**Bearing Adjustment, 27**

**Recommended Reading, 29**

**Gear Chart, 30**

**YOUR TREK FRAME, 31**

## PREFACE

Congratulations on choosing a Trek. Every effort has been made to ensure that your selection is the proper design and size for your special requirements. Your bicycle has been carefully constructed, assembled, and adjusted so that its safety and performance meet the highest standards. To ensure the continuation of these standards, we encourage you to read this manual thoroughly, giving special attention to the cautions for your personal safety. Your understanding of the operation and maintenance of your bike is your key to keeping it in top condition. This manual is designed to help you develop such an understanding. We do encourage you, however, to contact your Trek dealer if you have any questions concerning your new bicycle.

We have included a customer survey with the registration card you will need to fill out; your care in completing the survey will be of value to us in serving you and our other customers in the future. Comments and suggestions are always welcome. We're certain you'll enjoy your new bicycle—thank you for selecting Trek.

Your bicycle is a Black 22" 300  
Color Size Model No.

Your Trek dealer is \_\_\_\_\_ Phone: \_\_\_\_\_

# BEFORE YOU RIDE

Because a bicycle is smaller and less powerful than other vehicles, safety cannot be overemphasized. Here are suggestions that will help you ride your bike as safely as possible.

## **Make Sure Your Bicycle Fits You**

Your Trek dealer has fit you with the bicycle that will suit your needs best, one that can be ridden safely. A bicycle is considered unsafe for a particular person to ride if there is less than 1" clearance between the horizontal top tube and the rider when he or she is standing over the bicycle.

## **Know Your Bicycle Riding Laws**

Each state and local area has specific laws for cyclists. Local cycling clubs or your state's highway department should be able to supply this information to you. Using the proper hand signals, riding on the right side of the road (never going against traffic), and always riding in single file are among the more important rules. *Remember:* You are hard to see, and though cycling is becoming more and more prominent, many drivers simply are not trained to recognize the rights and special considerations of a bicycle rider. You *always* should ride your bicycle defensively and predictably.

## **The Road Itself Can Be a Hazard**

Road conditions and design have improved over the years, but you should always be aware of potential problems. Watch out for potholes, drain grates, soft or low shoulders, and other deviations. When crossing railroad tracks, do so carefully at a 90° angle. If you are not sure of conditions, walk your bike.

## **Parked Vehicles Are Potentially Treacherous**

Watch the cars you are preparing to pass. If the car suddenly enters your lane or someone opens a door unexpectedly, you could be involved in a serious accident. You may want to mount a horn or bell on your bicycle for added security in defensive riding.

## **Special Riding Situations Demand Special Attention**

Remember that the performance of your bicycle will change depending on the many conditions in which you will be riding.

**Night Riding.** Your Trek is equipped with a full set of reflectors; keep them clean and in position. As useful as these reflectors are, remember that they do not help *you* see, nor do they help you be seen unless light is directed on them. We strongly recommend that you use a good generator- or battery-operated head- and taillight assembly to augment the reflectors. Blinking or fixed lights that attach to either your arms or legs are an excellent purchase decision. *The important thing is to see and be seen.* A good number of products achieve this; if you do any amount of night riding, visit your dealer to see what's available.

**Wet Weather.** No brakes, whatever their design, work as effectively in wet weather as they do in dry. Wet weather precautions therefore must be taken. Brakes, even when properly aligned, lubricated, and maintained, require greater lever pressure and longer stopping distances in wet weather. Anticipate the extra time it will take to stop. Also remember that visibility (both yours and motorists') and traction are decreased. Wet leaves and drain grates are other hazards.

## **BEFORE YOU RIDE**

### ***Check Your Bicycle Visually Every Time You Ride***

To make sure your bike is ready to ride, spend a few moments checking its systems according to the checklist that follows. Keep in mind that this is *not* a comprehensive maintenance program. If your bicycle has some problem, or if you suspect it has been disturbed or tampered with, check the entire bicycle carefully or take it to your Trek dealer. If you are not certain as to what constitutes a problem, refer to the appropriate section of the Component Systems chapter. If you spot a problem, do not ride the bike until it has been corrected.

*Remember:* This is not a comprehensive maintenance checklist.

**Tires.** Inflate your tires to the air pressure recommended on the sidewalls. Gas station hoses inflate bicycle tires very rapidly, and the pressure they indicate is often inaccurate. We suggest that you use a hand-held pump and an appropriate gauge.

**Wheels.** Spin each wheel to see that it doesn't have flat spots and is centered in the bicycle frame or forks. Then grasp the rim and attempt to move the wheel to the right or left side of the bicycle. Wheels should be fixed and have no side-to-side play. If one or both wheels are not round or in their correct positions, refer to the Wheels and Tires section of the next chapter.

**Brakes.** Press each brake lever to make sure that there is no binding and that the brake shoes press hard enough on the rims to stop the bike. There should be no more than a  $\frac{1}{8}$ " clearance between the rim and each shoe. If your brakes are too tight or too loose, an adjustment should be made.

**Hub and Brake Quick Release Levers.** Make sure that all quick release mechanisms are in their closed (locked) positions.

## COMPONENT SYSTEMS

### Saddle and Seatpost

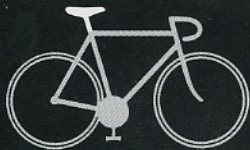

#### Assembly

The seatpost on your Trek has a clamp that is either separate from the post or an integral part of the post. To assemble the separate type, insert the small end of the seatpost into the saddle and clamp fixture. The post should be closer to the front of the bicycle than the two bolts used to adjust the assembly.

If your bike has the integral-type post, secure the saddle by tightening the two nuts on the left and right sides of the clamp. Or, if you have the micro-adjust type, tighten the single bolt underneath the clamp with a 6 mm hex wrench (Figure 1).

After assembling the saddle, post, and clamp, check to make certain that the seatpost is to the front of the clamp assembly and that the two steel support wires of the saddle are securely engaged in the runner sections of the clamp. Next, grease the seatpost and insert it into the bicycle frame seat tube, making sure that the *minimum insertion* mark engraved on the post is inside the seat tube and out of sight. **Caution:** Never ride your bicycle with the seatpost raised beyond the minimum insertion mark. A minimum of 2½" must always remain in the seat tube.

Affix the saddle assembly to the frame by tightening the

binder bolt with a 5 mm hex wrench. Make sure that the bolt or nuts of the saddle assembly are neither over- nor under-tightened. You should not be able to move the saddle from side to side or up and down. We recommend that the seatpost clamp nuts or bolt be tightened to 100"lbs (inch-pounds) and that the binder bolt be tightened to 80"lbs.

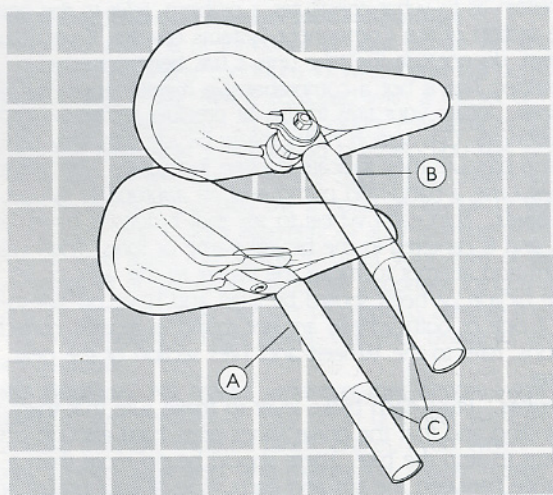

Figure 1. Saddle and seatpost

- (A) Micro adjust
- (B) Integral seatpost

- (C) Minimum insertion mark

## COMPONENT SYSTEMS

### **Position**

**Angle.** To adjust the angle of the saddle, you must first loosen the nuts or bolt on the seatpost clamp. The angle of the top plane of the saddle to the ground is a matter of personal preference; we recommend that you try it either parallel to the ground or tipped slightly to the rear. These positions will transfer weight off your arms and wrists for more comfortable riding. After adjusting the angle of the saddle, retighten the seatpost clamp as described in the Assembly section above.

**Height.** The height of the saddle is very important for riding comfort, safety, and efficiency. To set this position, loosen the binder bolt and position the crankarms so that they are perpendicular to the ground. While someone holds the bicycle up, place yourself on the saddle in riding position, without shoes. Adjust the height of the saddle so that your extended leg is straight when your heel rests on the pedal. Make sure that the minimum insertion mark remains inside the frame. Never ride the bicycle with the seat raised beyond this height. The correct seat position for you will allow the knee of your extended leg to be bent slightly when you are in a proper riding position with the ball of your foot on the pedal. After adjusting the height of the saddle, retighten the binder bolt as described in the Assembly section.



# COMPONENT SYSTEMS

## Handlebars and Stem



### Assembly

Slide the stem onto the handlebars until it is centered and positioned as shown in Figure 2. Tighten the handlebars on the stem with the handlebar clamp bolt. Next apply a liberal amount of grease to the lower portion of the stem, expander bolt, and wedge. Loosen the expander bolt with a 6 mm hex wrench and insert the handlebar assembly into the fork steerer tube so that the minimum insertion mark is not visible. **Caution:** Never ride your bicycle with the handlebar stem raised beyond the minimum insertion mark. A minimum of  $2\frac{3}{4}$ " of the stem always must be inside the fork steerer tube. Once the stem is in place, center it and tighten the expander bolt. The recommended torque for both the handlebar clamp bolt and the expander bolt is 100"lbs. **Caution:** Never ride a bicycle if the handlebar clamp or expander bolt is under- or overtightened. Test the security of the handlebars within the stem and the stem within the fork steerer tube by attempting to move the handlebars up and down and from side to side with the front wheel locked between your knees. If you are unsure of the safety of your handlebar system, do not ride the bicycle until your dealer has made any necessary adjustments.

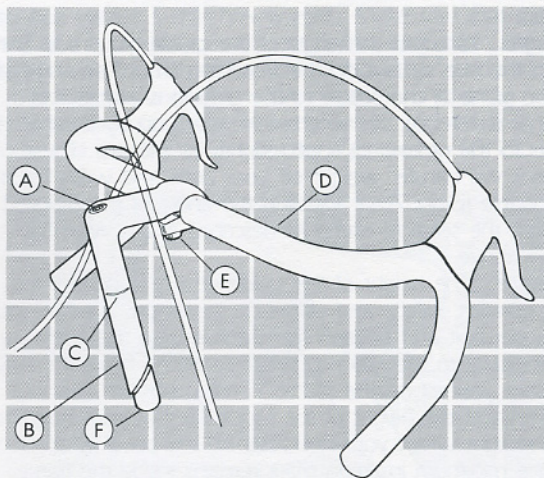

Figure 2. Handlebars and stem

- |                            |                |
|----------------------------|----------------|
| (A) Expander bolt          | (D) Handlebars |
| (B) Stem                   | (E) Clamp bolt |
| (C) Minimum insertion mark | (F) Wedge      |

### Position

**Angle.** Position the handlebars so that their ends point roughly toward the rear hub. When you adjust the handlebars, keep them centered in the stem and follow the directions and precautions in the Handlebar Assembly section above.

## COMPONENT SYSTEMS

**Height.** Handlebar height is largely a matter of personal preference, but usually handlebars are level with or slightly below the saddle height. Remember that at least  $2\frac{3}{4}$ " of the stem must remain in the fork steerer tube to ensure the strength and safety of the fork and stem assembly. Failure to observe this caution could result in bodily injury.

To raise or lower the handlebars, loosen the stem binder bolt two or three turns and then tap it down to loosen the wedge. Use a soft-face hammer or a block of wood to protect the finish. When repositioning the stem, follow the directions outlined in Assembly, with special attention to the precautions.

## COMPONENT SYSTEMS

### The Drivetrain



The drivetrain refers to parts of the bicycle that transmit power to the rear wheel. The system includes the pedal and toeclip assembly, crankset, chain, and freewheel (see Figure 3). When the components of this system are working together properly, shifting will be easy, your bike will be quiet, and its efficiency can reach its maximum. The discussion of function and basic maintenance that follows will help you keep your bicycle running smoothly. For more information about the drivetrain, refer to the Appendix or contact your Trek dealer.

#### Pedals and Toeclips

**Assembly.** Each pedal is stamped *R* or *L* on one of the flat sides of the pedal spindle. Apply grease to the pedal threads and screw the pedal marked *R* clockwise into the crankarm on the right side of the bicycle. Screw the other pedal counterclockwise into the crankarm on the left side of the bicycle. Be careful not to confuse the two pedals; damage to both pedal threads and the crankarms can result. Tighten both pedals securely—we recommend a torque of 350" lbs.

Attach each toeclip to a pedal with the bolts that are

integral parts of the pedal reflectors. Sandwich the toeclip between the pedal surface and the reflector (see Figure 3) and fasten it to the pedal with the lock washers and nuts. Feed each toeclip strap through the pedal slots, then through the slot in the toeclip cage. Buckle the strap.

**Operation.** Getting on and off a bicycle equipped with toeclips is a little tricky at first, but with just a little practice it becomes extremely easy. First straddle the bike with both feet flat on the ground. Position the left pedal up toward the handlebars. After making sure that both toestraps are open wide

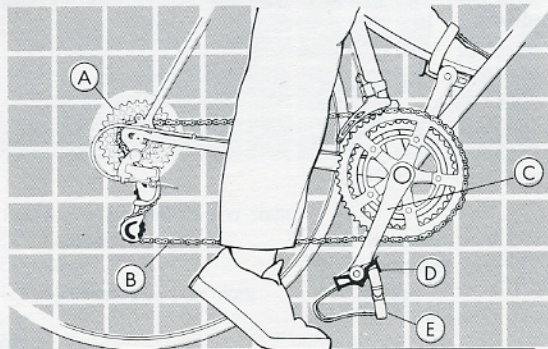

Figure 3. The drivetrain

- (A) Freewheel
- (B) Chain
- (C) Crankset

- (D) Pedal
- (E) Toeclip assembly

## COMPONENT SYSTEMS

enough to accept your shoes, place your left foot in the left clip, push forward, and mount the saddle. Flip the right toeclip rightside up by drawing your foot across the small tab on the bottom of the cage and place your right foot in the right clip. As you pedal along, reach down and tighten the straps.

Toeclips will increase your efficiency and power a great deal because you are able to pull up on the toeclip cages as well as push down on the pedals. They also prevent your feet from slipping off the pedals when they are wet or when you apply a great deal of pressure. Although toeclips are an accessory, we highly recommend them. **Caution: Always remember to release the straps before coming to a complete stop.**

### The Crankset

**Function.** The crankset includes the left and right crankarms, the bottom bracket set (axle and bearing assembly), and the chainrings. Your bicycle is equipped with either two or three chainrings, depending on the model. The number of teeth on the chainrings has been chosen according to the type of riding for which your particular model was designed. Optimal gearing has been supplied on your Trek. If you would like to revise the gearing provided on your bicycle, the chainrings can be changed, as can the cogs on the freewheel; refer to the Gear Chart in the Appendix.

**Inspection.** Periodically check the teeth on each chainring for excessive oil buildup and bent or broken teeth. These problems can make shifting noisy and ineffective or cause the chain to fall off. Also check the

tightness of the *crankarm fixing bolts* from time to time. Remove the dustcover with a coin and tighten the crankarms with the correct socket wrench (14 or 15 mm). The recommended torque is 220"lbs. Finally, check the side-to-side play in the crank. Take the chain off the chainrings, place your hand on each crankarm, and pull to the left and right of the bicycle. There should be no visible rocking motion. If there is, the bearings are too loose. Next, spin the crank. If the motion stops abruptly, the bearings are too tight. If the crank is either too loose or too tight, refer to the Bearing Adjustment section of the Appendix.

### The Chain

**Cleaning and Lubrication.** Keep the chain as free of dirt as possible. After cleaning with a brush and kerosene (do *not* use gasoline), allow the chain to air dry and then apply the proper bicycle oil. Keep in mind that excessive oil on the chain will attract more dirt. Take the extra time to apply oil only to the pivot points of each link.

### The Freewheel

**Cleaning.** Just like the chain, the freewheel should be kept as clean as possible. Remove the surface dirt that gathers around the cog teeth with kerosene and a brush. Do *not* use gasoline. To clean and lubricate the bearings, you'll have to remove the freewheel unit from the hub. Directions for this operation are included in the Appendix.

## COMPONENT SYSTEMS

### The Derailleur System

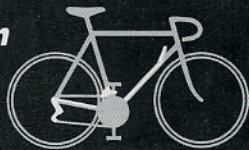

#### Function and Operation

The word *derailleur* refers to the derailing or shifting of the chain from one sprocket to another. The derailleur system includes the front and rear derailleurs, the shift levers, and the cables (Figures 4 through 7). A variety of gear ratios allows you to maintain a constant rate of pedal revolutions in spite of changes in terrain, weather, and your physical condition.

When shifting gears on a bicycle, plan ahead—you can shift gears only while the pedals and chain are moving forward. Never attempt to shift gears when stopped or when back pedalling. When you shift, reduce your pressure on the pedals; excessive chain tension makes shifting difficult. Avoid shifting when going over railroad tracks or other bumpy surfaces, or the chain may not shift properly and may come off.

The gear shift levers, Figure 4, are operated by fingertip control. The left-hand lever controls the front derailleur mechanism, and the right-hand lever controls the rear. Shift only one lever at a time. Choose the gear combination most comfortable for the road conditions, and you should be able to maintain a constant rate of pedalling. It is not essential that various gear combinations be used in sequence.

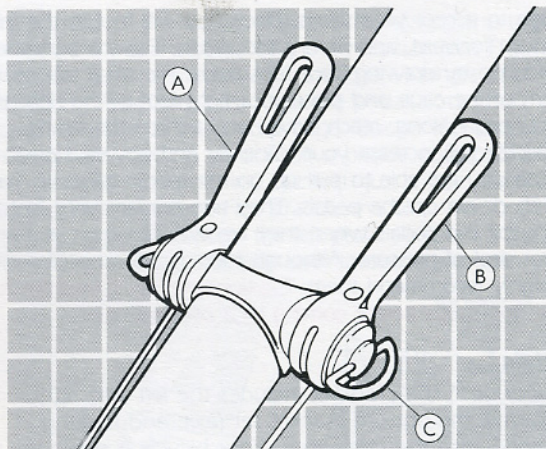

Figure 4. Shift levers

- (A) Front derailleur lever
- (B) Rear derailleur lever
- (C) Friction screw

Listen to your bike. A properly adjusted drivetrain and derailleur system is *quiet*. If an unusual noise accompanies or follows any shift, try moving the levers slightly; you will soon learn to make fine adjustments while riding along. If the noise persists or grows louder, stop the bicycle and try to locate the noise. If necessary, ask your Trek dealer to identify and correct any problems.

## COMPONENT SYSTEMS

### Adjustment

If shifting is sluggish or difficult, if you hear a rubbing or grinding noise, or if the chain rubs on any part of the bicycle or falls off during or after a shift, check the adjustment of the derailleurs. The rear derailleur (Figure 5) should be checked and adjusted first because the front derailleur (Figure 7) cannot be aligned if the rear mechanism is out of adjustment.

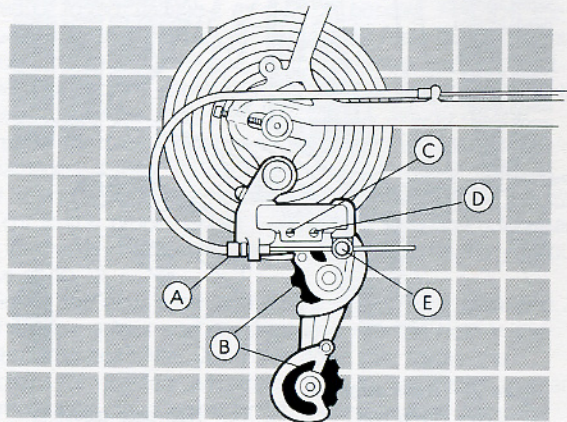

Figure 5. Rear derailleur

- |                              |                               |
|------------------------------|-------------------------------|
| (A) Adjusting barrel         | (D) High gear adjusting screw |
| (B) Derailleur pulleys       | (E) Cable clamp bolt          |
| (C) Low gear adjusting screw |                               |

**Rear Derailleur.** To make the high gear adjustment on the rear derailleur, first shift the chain onto the smallest rear sprocket and the smallest front chainring, then loosen the *cable clamp bolt* until the cable is free. Once this is done, stand behind the bicycle to see that the smallest rear sprocket, the chain, and the two derailleur pulleys are in line (see Figure 6).

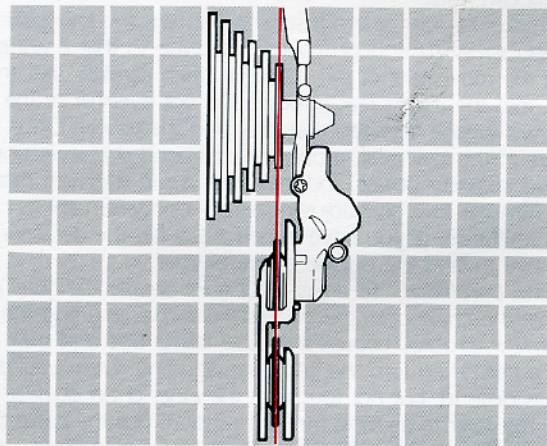

Figure 6. Rear derailleur alignment

When adjusting rear derailleur, pulleys should be on same plane as the smallest freewheel sprocket.

## COMPONENT SYSTEMS

If they aren't aligned, turn the *high gear adjusting screw* until this line is established. Next, move the right-hand shift lever to its most forward position and screw the adjusting barrel all the way in (not all models have an adjusting barrel). Pull the cable taut and tighten the cable clamp bolt to approximately 30"lbs. Be careful not to over- or undertighten—bolt damage or cable slippage can result.

To make the low gear adjustment, first turn the *low gear adjusting screw* far enough counterclockwise so that it will not restrict the movement of the derailleur. Then *carefully* shift the chain onto the largest rear sprocket. Do not overshift or the chain will wedge between that gear and the wheel. Once you are in the low gear, move the right-hand shift lever until the two derailleur pulleys and the chain are in line with that gear. Turn the low gear adjusting screw clockwise until it meets resistance. (If you have turned it too far, the derailleur will move toward the outside of the bicycle).

**Front Derailleur.** To adjust your front derailleur (Figure 7), first shift the chain onto the smallest front chainring and the largest rear sprocket. Loosen the cable clamp bolt until the cable is free. Then turn the low gear adjusting screw until the chain is close to, but not touching, the inner chain guide. Move the lever to its most forward position, pull the cable taut, and tighten the cable clamp bolt. Be careful not to under- or overtighten; we recommend tightening to 30"lbs.

To adjust the derailleur for the outside chainring, shift the rear derailleur to the smallest sprocket. Next, turn the high gear adjusting screw counterclockwise until it cannot interfere with the motion of the derailleur. Shift the chain onto the large

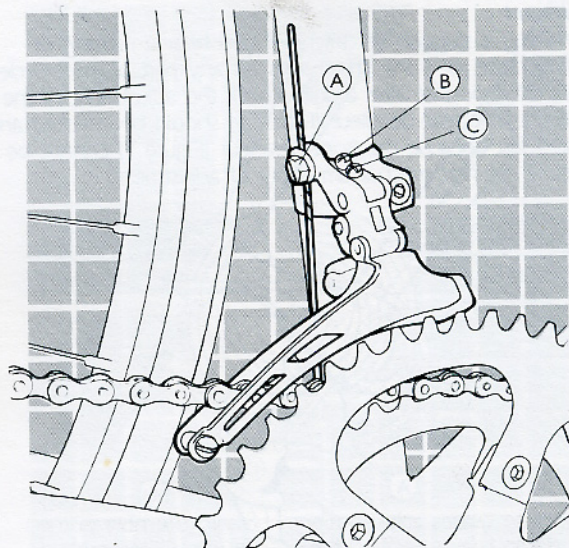

Figure 7. Front derailleur

- (A) Cable clamp bolt
- (B) Low gear adjusting screw
- (C) High gear adjusting screw

outside chainring and position the derailleur so that the chain is close to but not touching the outer chain guide. Retighten the adjusting screw until it meets resistance. Go through the various gear combinations. Make sure the chain does not fall

## COMPONENT SYSTEMS

off when you shift and that the derailleurs do not rub on any part of the wheel or crankset. Finally, make sure that the cable has not slipped.

**Shift Levers.** If a shift lever is too tight to move easily or is so loose that it moves back to the forward position after a shift, then the friction screw needs to be adjusted. See Figure 4.

**Cable Replacement.** If the cable of either derailleur is frayed or rusted, replace it as soon as possible. First shift the derailleurs so that both levers are in their most forward position. Loosen the cable clamp bolt for the derailleur with the bad cable and feed the cable through the shift lever and off of the bicycle. Notice the path the cable follows as you do this.

Inspect the cable housings to see if they are clean and undamaged. If they are damaged or rusty, replace them as well. If you replace any housings, make sure that the pieces are cut to the proper length (use the old pieces as guides) and that neither end has burrs; the cable should pass freely through these ends.

Grease the new cable and feed it through the lever and all of the cable guides and housings and into the hole in the cable clamp bolt. After you have done this, follow the directions for derailleur adjustment and cut the cables so that no more than 3" of cable length extend beyond the cable clamp bolt. To prevent fraying, crimp on a metal end cap or apply some solder to the end of the cable.



# COMPONENT SYSTEMS

## Wheels and Tires



### Quick Release Units

Your bicycle features quick release levers on both brakes and both hubs. These levers let you remove and install wheels without deflating the tires or using tools. **Caution: Read this section carefully. If any of the release mechanisms are improperly adjusted or disengaged, the bicycle is unsafe to ride.**

Front and rear brakes have separate quick release levers. Depending on your model, these quick release levers are either on the hand brake lever or on the caliper brake arm (Figures 8 and 9). To operate the quick release on a hand brake lever, squeeze the brake until the quick release lever can be pushed to the side, then release the hand brake lever. The brake calipers will open wide enough to allow the inflated tire to pass through. To reset the quick release, squeeze the brake lever until the quick release lever can be pushed back in line. Align the quick release and brake levers. Release the brake lever and check brake adjustment.

To operate the quick release on a caliper brake arm, pull the quick release lever out and away from the frame. To reset the quick release lever, push it back toward the frame while squeezing the brake calipers lightly.

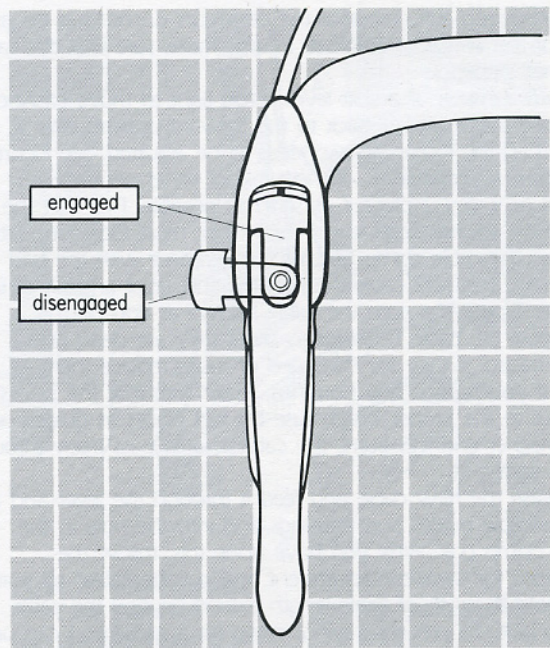

Figure 8. Brake lever equipped with brake quick release lever

## COMPONENT SYSTEMS

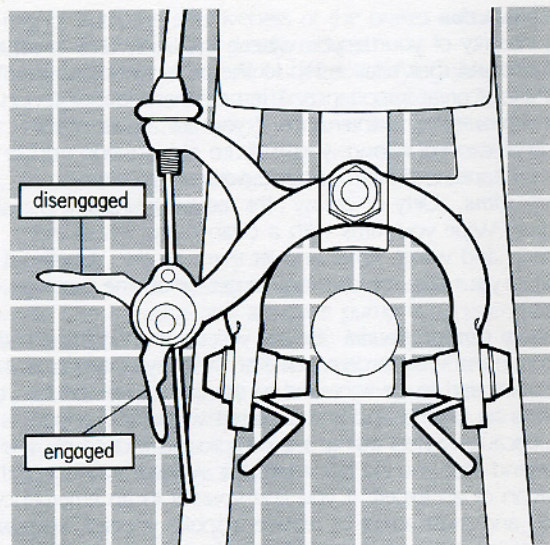

Figure 9. Brake caliper equipped with brake quick release lever

**Front Wheel Removal.** Disengage the front brake quick release lever and open the hub quick release skewer by pulling the skewer lever away from the wheel and turning it 180° toward the front of your bicycle (see Figure 10). Slip the wheel out of the fork.

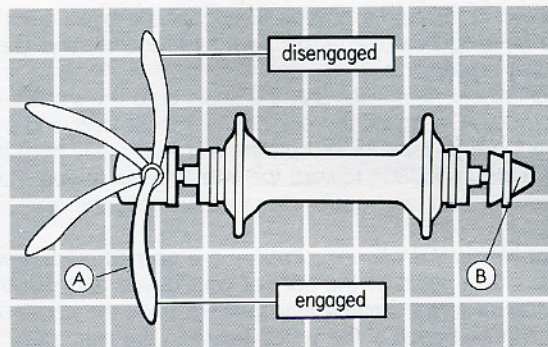

Figure 10. Hub quick release

(A) Skewer lever

(B) Skewer adjusting nut

**Front Wheel Installation.** Position the opened quick release lever so that it is on the left side of the bicycle and points toward the front. Next, guide the axle into the fork slots, being careful to not knock the brake shoes loose. After making sure the axle is inserted all the way into the slots, center the wheel between the fork blades. Tighten or loosen the adjusting nut opposite the lever until you can easily turn the lever about half way back to the closed position, or until it is parallel to the axle. Push the lever all the way to the rear to lock the wheel securely in place. *Test the lever.* If you can rotate the lever up and down, it is too loose. Reopen the quick release lever and tighten the adjusting nut until you can't rotate the lever up

## COMPONENT SYSTEMS

and down in the closed position. Reengage the brake quick release lever. Squeeze the brakes tightly a few times and check for proper adjustments.

**Rear Wheel Removal.** Shift the chain onto the smallest rear sprocket. Disengage the brake quick release lever and pull the quick release lever located on the rear hub away from the wheel and turn it 180° toward the front of your bicycle. Pull the derailleur back and up for clearance. Remove the rear wheel.

**Rear Wheel Installation.** Position the opened quick release lever so that it points to the front of your bicycle and shift the rear derailleur to the smallest rear sprocket. Pivot the derailleur to the rear and position the wheel between the rear chainstays. Guide the chain onto the smallest rear sprocket. Slide the wheel into the rear dropouts, release the derailleur, and center the wheel in the frame. Next, tighten or loosen the adjusting nut opposite the lever until you can easily turn the lever about half way back to the closed position, so that the lever is parallel to the axle. Push the lever all the way to the rear to lock the wheel securely in place. Finally, *test the lever*. It is too loose if you can rotate it up and down; reopen the lever and tighten the adjusting nut as described under Front Wheel Installation, then reengage the brake quick release lever and test your brakes. **Caution: Make sure your wheels are centered and spin freely without grabbing or rubbing against your brake shoes.**

### **Wheel Inspection**

The integrity of your bicycle wheels is crucial. Their structural soundness and their relationship to the performance of your brakes are of great importance. The best maintenance for a wheel is preventive maintenance. If you are aware of the things that *can* go wrong, you may be able to stop trouble before it happens. Watch for these potential problems:

**Dirty Rims.** Dirty or greasy rims render your brakes ineffective. Wipe your rims with a clean rag or wash them with soap and water, rinse, and let them air dry. When lubricating your bike, be sure not to get oil on the braking surfaces.

**Wheels Out of Round.** Bicycle wheels must withstand the great force and weight demanded of them by a cyclist, and the spokes need to be tightened to the correct tension for your wheels to be both round and centered within the bicycle frame. Because wheel truing is a complicated procedure, we recommend that you do not attempt it without training or the supervision of an expert. If you find yourself in an emergency situation and must adjust or replace a spoke yourself, keep in mind that loosening a spoke radiating from one side of the hub will move the rim toward the other side. Conversely, if you tighten a spoke, the rim will move toward the side of the hub to which the spoke is attached. If a spoke attached to the right side of the rear hub breaks, you will need to remove the freewheel; refer to the Appendix for this operation.

Inspect your wheels frequently to make sure that there are no loose, damaged, or broken spokes. **Remember:** If a wheel is

## COMPONENT SYSTEMS

not round, both the effectiveness of the brakes and the strength of the wheel are greatly reduced.

**Too Much Play in the Hub.** After satisfying yourself that the hub quick release units are engaged properly, check the play in the hub by attempting to move the wheel to the left and right. If there is too much play between the axle and the hub, an adjustment should be made. This procedure is explained in the Appendix.

### **Tire Inspection**

Keep your tires inflated to the pressure molded on the sidewalls. Use a gauge and a bicycle pump whenever possible. Avoid filling your tires at gas stations; because of the greater pressure and volume of air their pumps release, blowouts are very possible. When you fill your tires, check to see that each tire is properly seated in the rim and that there are no defects on its surface. If a tire shows signs of dry rot or if it is badly cut, replace it as soon as possible.

### **Valves**

Your bicycle tubes have *Presta valves*. To inflate a tire, remove the protective valve cap and turn the small valve lock nut counterclockwise as far as it will go. The tube will then accept air. After inflating the tire, turn the lock nut clockwise all the way and replace the cap. If you would like to use a pump designed for Schraeder or car-type valves, adapters can be purchased at your Trek dealership.

# COMPONENT SYSTEMS

## The Brake System



### Brake Lever Installation

Attach your brake levers to the handlebar assembly by opening the circular clamp underneath each lever enough to allow them to slide onto the handlebars and into position. Position the levers carefully. If they are mounted too high on the handlebars, you will have trouble reaching them; if they are too low, they will hit the handlebars as you squeeze your brakes, inhibiting effective braking. Also make sure that one lever is not higher or lower than the other. After you have positioned the levers, secure them by tightening the *clamp pull-up nuts* inside the lever bodies. The recommended torque is 60" lbs.

When brake lever installation is complete, wrap the handlebars with handlebar tape. You'll need two rolls. Beginning each roll approximately 3" from the stem, work out toward the ends. Overlap about  $\frac{1}{3}$  of the tape's width on each pass around. When you reach the ends, curl the tape inside the handlebar openings and secure it in place with the handlebar end plugs.

### Operation

The brake system consists of a lever, cable, and caliper for each wheel. Your bike is equipped with either caliper or cantilever brakes (Figures 11 and 12).

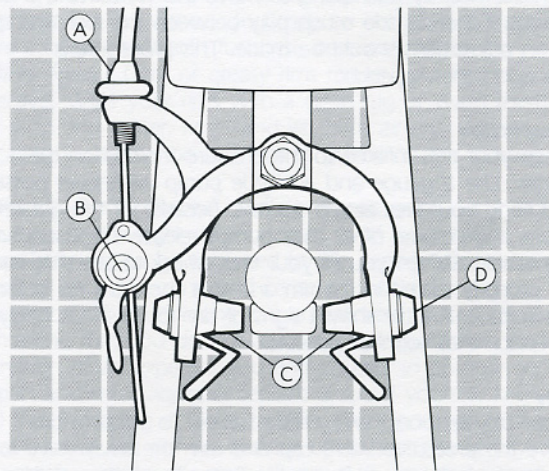

Figure 11. Caliper brake

- |                            |                           |
|----------------------------|---------------------------|
| (A) Cable adjusting barrel | (C) Brake shoes           |
| (B) Cable anchor bolt      | (D) Brake shoe anchor nut |

Do not ride your bicycle if you are not certain that both the front and the rear units are working properly. If you question

## COMPONENT SYSTEMS

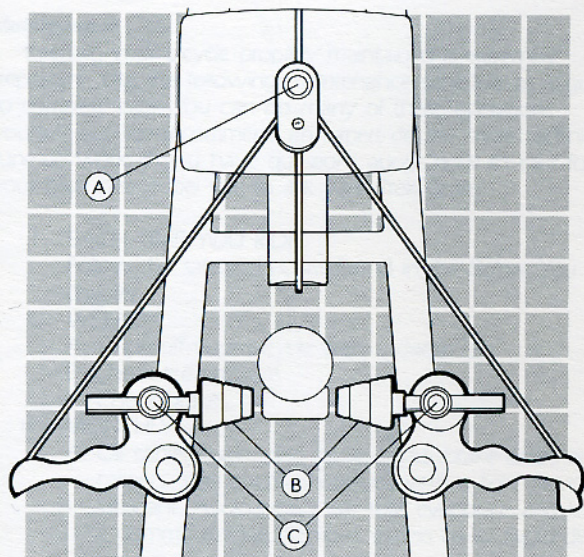

Figure 12. Cantilever brake

- Ⓐ Cable anchor bolt
- Ⓑ Brake shoes
- Ⓒ Brake shoe anchor nuts

the soundness of your brake system, take your bicycle to your Trek dealer. Expertise is required; however, if you feel that you can adjust this system yourself, refer to the Adjustment

section below.

When stopping, always apply the rear brake first. Avoid braking while turning, or the bike may skid out of control. Also remember that any brakes are less effective in wet weather. Review the Before You Ride chapter for general safety checks.

### Adjustment

Make sure that the front ends of all four aluminum brake shoe holders are closed, so that the rubber brake shoes do not slide out when you apply the brakes. Squeeze the brakes and inspect the shoes to see if they touch the sides of the wheel rims completely and do not rub on the tires. If necessary, loosen the brake shoe anchor nuts and move the shoes until they are in the correct position. Retighten the anchor nuts firmly; the recommended torque is 50"lbs.

In normal riding position, each brake shoe should clear the rim by approximately  $\frac{1}{16}$ " to  $\frac{1}{8}$ " on each side. If the shoes are not this close, turn the cable adjusting barrel until the desired clearance is achieved. Do not turn the adjusting barrel past the end of the threads.

If the brake cannot be adjusted this way, screw the adjusting barrel all the way down. Hold the brake shoes against the rim, loosen the cable anchor bolt, and pull the cable tight. Retighten the cable anchor bolt enough to prevent the cable from slipping when the brakes are applied. Be careful to not overtighten and strip the threads; the recommended torque is 30"lbs. Test the brakes by squeezing the lever as hard as possible several times, then check the brake adjustment as before.

# COMPONENT SYSTEMS

## **Cable Installation**

Periodically check the cables for kinks, rust, broken strands, and frayed ends. Also check the housing for bent ends, crimped holes, stretched coils, and wear. If you see any of these things, replace the cable and/or housing as soon as possible.

First, loosen the brake cable anchor bolt and feed the cable out through the brake lever. Grease the new cable and reinstall, feeding it in along the same path. Make sure that the cable's lead fitting is seated properly in the brake lever body and that the housing and *ferrule* (the small aluminum fitting) are properly seated in the top portion of the lever. After threading the cable through the anchor bolt, follow the directions for adjustment above. Be sure to adjust the brakes so that they work properly when the brake quick release mechanism is in the closed or locked position. Finally, cut the cable so that no more than 3" extend beyond the anchor bolt; crimp a metal cap or place a bit of solder on its end to prevent fraying.

## **Brake Shoe Installation**

When brake shoes become noticeably worn or hard, they must be replaced. Remove the old shoes with the appropriate wrench, put the new ones on, and align them so that they strike the rim completely. Make sure they don't touch the tire. You probably will need to readjust the cable to accommodate the difference in pad width—shoes get thinner with wear. Always maintain the  $\frac{1}{16}$ " to  $\frac{1}{8}$ " clearance between the shoes and the rim.

# BICYCLE CARE

## Maintenance

Keeping your bicycle properly maintained is extremely important. Use the following maintenance schedule as a guide to complete care. You can do many of these operations yourself, but we recommend an expert do the more technical tune-up work. If you have questions about how to care for your bike, please feel free to ask your Trek dealer.

- I. EACH TIME YOU RIDE  
Follow the safety checklist found in the Before You Ride chapter.
- II. WEEKLY
  - A. Wipe off your bicycle with a damp rag.
  - B. Check tire pressure.
  - C. Check brakes.
- III. MONTHLY
  - A. Oil cable, chain, and pivot points (brake levers and calipers, shift levers, derailleurs) with a light bicycle lubricant. Avoid heavy oils that evaporate and leave a gummy residue. Remove excess oil to avoid dirt buildup.
  - B. Tighten any loose nuts and bolts.
- IV. TWO, THREE, OR FOUR TIMES A YEAR
  - A. Check wheels and have the bicycle shop true them if necessary.
  - B. Replace brake shoes if they are worn down past the grooves.

- C. Clean chain, derailleurs, and other greasy parts with a brush and kerosene and then relubricate.
- D. Check gear adjustments.
- E. Clean and wax finish.
- V. EVERY YEAR OR TWO
  - A. Clean all bearings in the hubs, bottom bracket, and headset. Repack bearings with grease. Oil or grease pedal bearings.
  - B. Replace frayed cables.
  - C. Replace tires if they are split or if cord can be seen anywhere.

This maintenance schedule is based on normal usage. If you ride your bike more or less than average, you will want to go over your bicycle more or less often than the schedule suggests. If any part appears to be malfunctioning, check and adjust it immediately if you can do so yourself, or consult your Trek dealer. Never ride any bicycle that is not operating properly.

## Storage

Improper storage is very hard on a bicycle. Before storing your bike, clean, lubricate, and wax it. Hang the bicycle off the ground, with the tires at approximately half pressure. Do not store near electric motors (ozone destroys rubber and paint). Before riding the bicycle again, be certain it is in good working order.



## BICYCLE CARE

### **Security**

The greatest hazard you may face with your bicycle is the risk of having it stolen. Take every precaution you can:

1. Keep a record of the serial number in a safe place.
2. Register the bicycle with your local police.
3. Purchase a lock from a manufacturer that guarantees its absolute effectiveness against bolt cutters and saws.
4. Use your lock. *Never*—not even for a minute—leave your bicycle unlocked.

## APPENDIX

### **Clincher Tire Repair/Replacement**

Follow the steps below when you need to replace a tube or tire. Your Trek dealer will be glad to help you if you need assistance.

1. Remove the wheel from the bicycle. Review the section on Quick Release Units in the Component Systems chapter.
2. Open the valve and, holding it open, squeeze out air to completely deflate the tire.
3. By pushing inward, loosen the tire bead from the rim all the way around.
4. Pry one side of the tire bead up over the edge of the rim. *Note:* Use tire tools or other smooth-ended tools. Don't use a screwdriver—you may damage the tire and tube.
5. Remove the tube, leaving the tire on the rim.
6. Locate any leaks and patch according to the instructions in the patch kit or replace the tube if necessary.
7. Match the tube with the wheel to possibly locate the cause of the puncture in the tire. Mark the location.
8. Remove the tire from the rim and check it to determine the cause; a nail or piece of glass may still be in the tire. Inspect the whole tire and rim for damage. Correct or replace before reinstalling the tire.
9. Remount one side of the tire on the rim.
10. With a hand pump, put enough air in the tube to give it some shape.
11. Put the valve stem through the hole in the rim and work the tube into the tire. Do not let it twist.
12. Without using tools, push the second side of the tire on the rim. Start in one spot and work in both directions. You may have to stop and let some air out of the tube.
13. To get the last few inches on the rim, keep tight pressure on the tire to slide it over the rim with the palm of one hand. Using tools is a great temptation, but avoid them. They can damage the tire, break the wire bead, and puncture the tube. If you cannot get the tire on without using tools, take it to your Trek dealer.
14. Check that the tube is not caught between the tire bead and the rim at any point.
15. Inflate the tire to 25 pounds and check the tire for proper seating. Make sure that the tire bead sits in the rim to the same depth at all points. If properly seated, inflate to the pressure stamped on the side of the tire.
16. Reinstall the wheel, check gears, brakes, and quick release levers.

### **Mounting Sew-up Tires**

1. Clean the old glue from the rim with a solvent such as acetone or lacquer thinner. Dry the rim.
2. For easier mounting, stretch the new tire by looping it under your foot and pulling up firmly with both hands.
3. Apply a moderate layer of sew-up mounting glue evenly over the rims.
4. Insert the valve into the rim and slowly pull the tire onto the rim. You may need to anchor the wheel between your feet, valve side down, while pulling the tire up and sliding it on the rim with both hands.

## APPENDIX

- When the tire is completely mounted, add 40 pounds of air. Center the tread on the rim so that it tracks straight and evenly.
- Inflate the tire to full pressure and recheck alignment. If the tread becomes uneven, deflate to 40 pounds and restraighten.
- Wipe any excess glue off the rims and tire sidewall.
- Allow one day for setup.
- Check to make sure that you cannot roll the tire off with your hands.

### The Freewheel

**Removal.** Removing the freewheel is necessary if you need to change a spoke that radiates from the right flange, to adjust the bearings, or to clean and lubricate the freewheel itself. Before trying to remove your freewheel, determine its type. Trek bicycles are equipped with either a Helicomatic or a standard freewheel system. The word *Helicomatic* is printed on the surface of the rear hub body if it is of this type. If there is no marking, the freewheel is the standard type.

To remove the Helicomatic freewheel (see Figure 13), loosen and remove the knurled nut with the special spanner wrench and simply pull the freewheel away from the hub. There is no need to remove the skewer. To separate the standard-type freewheel from its hub (Figure 14), remove the skewer and place the freewheel tool on the freewheel so that its tangs fall into the notches in the freewheel body. Hold the tool in this position by inserting

the skewer through the opening in the tool and through the hub. Do not tighten the skewer more than necessary to prevent the freewheel tool from falling out of the freewheel notches. Secure the freewheel tool in a vise and apply pressure counterclockwise until the wheel begins to turn. When you feel this initial movement, remove the skewer and unscrew the freewheel by turning the tool counterclockwise.

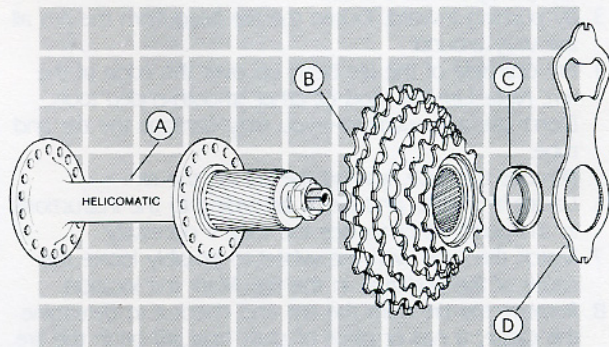

Figure 13. Helicomatic hub and freewheel

- (A) Hub body
- (B) Freewheel
- (C) Knurled security nut
- (D) Helicomatic spanner wrench

## APPENDIX

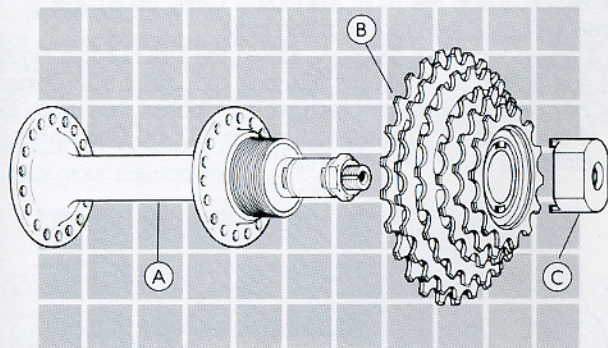

Figure 14. Standard hub and freewheel

- (A) Hub body
- (B) Freewheel
- (C) Freewheel tool

**Cleaning and Lubricating.** To clean the bearing surfaces, soak the freewheel overnight in a clean solvent such as kerosene and allow to air dry thoroughly. Lubricate the bearings by dripping a middle-weight bicycle oil into the freewheel body. Spin the freewheel so that the oil reaches all of the bearing surfaces. Do *not* disassemble the freewheel.

**Installation.** To reinstall the Helicomatic freewheel, simply push it back onto the hub and tighten the knurled lock nut back into place with the special spanner wrench. For the standard type, grease the threads and screw the freewheel

clockwise onto the hub until it is hand-tight and replace the quick release skewer.

### **Bearing Adjustment**

Cone adjustment may occasionally be needed on the headset, crank assembly, and hubs without sealed bearings. Poorly adjusted bearings can cause damage and be very unsafe. Your Trek dealer has the proper tools and expertise to make these adjustments for you. If you would like to do the work yourself, use the following basic guidelines.

**Headset.** Check excessive play in the headset by trying to rock the fork back and forth with one hand on either fork blade and the other on the handlebar stem. If you feel more than just a slightly discernable amount of play, the bearings are too loose. Check for insufficient play by slowly pivoting the fork to the left and right; if the fork sticks or binds anywhere, the bearings are too tight.

To adjust the headset, loosen the lock nut (see Figure 15) and then tighten or loosen the adjusting cone until it is touching but not pressing on the bearings. Then back the adjusting cone off  $\frac{1}{8}$  to  $\frac{1}{4}$  of a turn. Retighten the lock nut (recommended torque is 100"lbs) and check the adjustment.

**Crankset.** To check the crankset adjustment, shift the chain to the small chainring and the smallest freewheel sprocket. Remove the chain from the chainring and rest it on the bottom bracket. Set the crankset in motion and watch to see that it spins freely. If it comes to an abrupt stop, the bearings are too tight. To check for excessive play, grasp each crankarm and attempt to rock the crankset to the left and right sides of

## APPENDIX

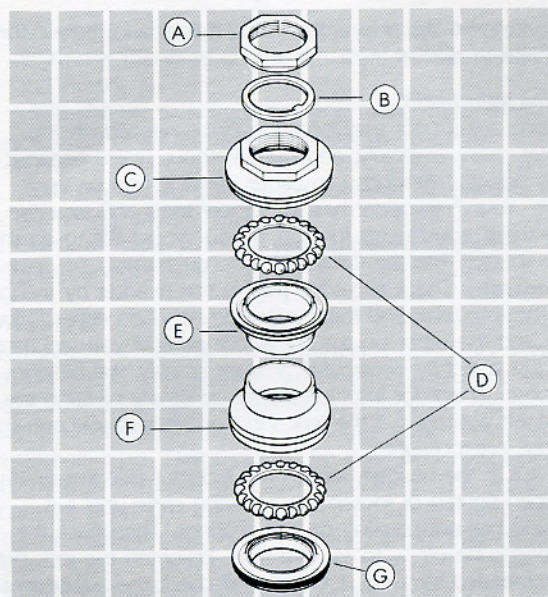

Figure 15. Headset

- |                        |                      |
|------------------------|----------------------|
| (A) Lock nut           | (E) Top head race    |
| (B) Lock washer        | (F) Bottom head race |
| (C) Adjusting cup/cone | (G) Crown race       |
| (D) Bearings           |                      |

the bicycle. If you feel more than just a barely discernable amount of play, the crankset is too loose.

If an adjustment is necessary, loosen the lock nut (see Figure 16) and tighten or loosen the adjusting cup until it is touching but not binding the crank bearings. Then loosen the cup  $\frac{1}{8}$  to  $\frac{1}{4}$  of a turn and tighten the lock nut to 150"lbs. Check your adjustment and remount the chain.

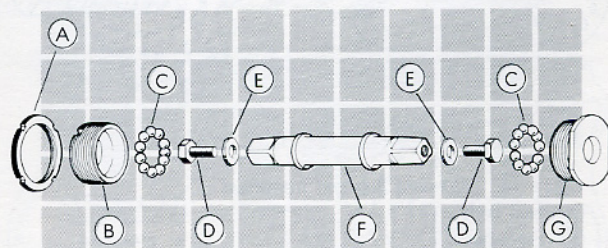

Figure 16. Crankset

- |                   |                     |
|-------------------|---------------------|
| (A) Lockring      | (E) Crankarm washer |
| (B) Adjusting cup | (F) Spindle         |
| (C) Bearings      | (G) Fixed cup       |
| (D) Crankarm bolt |                     |

**Wheels.** Wheel bearings should be adjusted if the wheel does not spin freely or if there is a rocking motion when you move the wheel from side to side. If you are working with the rear wheel, you will need to remove the freewheel; refer to the preceding section for directions.

## APPENDIX

Before adjusting the cones, check to make sure that the lock nut opposite the side you are working on (see Figure 17) is tightened to the required pressure—70"lbs. Then loosen the lock nut on the side you are working on and turn the cone until it touches but does not bind the bearings. Back the cone off  $\frac{1}{8}$  to  $\frac{1}{4}$  of a turn and tighten the lock nut to 70"lbs. Check your adjustment.

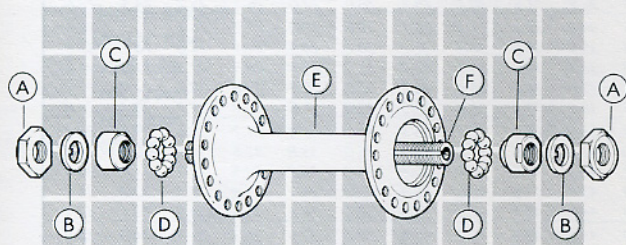

Figure 17. Hub bearings

- (A) Lock nut
- (B) Lock washer
- (C) Cone

- (D) Bearings
- (E) Hub body
- (F) Axle

### Recommended Reading

- The All New Complete Book of Bicycling.* Eugene A. Sloane (rev. ed.), 1981 (ISBN 0-671-24967-3), Simon and Schuster.
- Anybody's Bike Book: An Original Manual of Bicycle Repairs.* Tom Cuthbertson (rev. ed.), 1979 (ISBN 0-89815-003-5), Ten Speed Press.
- Delong's Guide to Bicycles and Bicycling.* Fred Delong, 1978 (ISBN 0-8019-6686-8), Chilton.
- Richard's Bicycle Book.* Richard Ballantine, 1975 (ISBN 0-345-29453-x), Ballantine.
- The Ten Speed Bicycle.* Michael J. Kolin and Denise M. De la Rosa, 1979 (ISBN 0-87857-281-3), Rodale Press.

# APPENDIX

**Gear Chart** (inches traveled per one turn of the crank)

	Rear Freewheel Teeth																				
	12	13	14	15	16	17	18	19	20	21	22	23	24	25	26	27	28	29	30	31	32
<b>24</b>	54.0	49.8	46.3	43.2	40.5	38.1	36.0	34.1	32.4	30.9	29.5	28.2	27.0	25.9	24.9	24.0	23.1	22.3	21.6	20.9	20.3
<b>25</b>	56.2	51.9	48.2	45.0	42.2	39.7	37.5	35.6	33.8	32.1	30.7	29.3	28.1	27.0	26.0	25.0	24.1	23.3	22.5	21.8	21.1
<b>26</b>	58.5	54.0	50.1	46.8	43.9	41.3	39.0	36.9	35.1	33.4	31.9	30.5	29.2	28.1	27.0	26.0	25.1	24.2	23.4	22.6	21.9
<b>27</b>	60.8	56.1	52.1	48.6	45.5	42.9	40.5	38.4	36.5	34.7	33.1	31.7	30.4	29.2	28.0	27.0	26.0	25.1	24.3	23.5	22.8
<b>28</b>	63.0	58.2	54.0	50.4	47.3	44.5	42.0	39.8	37.8	36.0	34.4	32.9	31.5	30.2	29.1	28.0	27.0	26.1	25.2	24.4	23.6
<b>29</b>	64.2	60.2	55.9	52.2	48.9	46.1	43.5	41.2	39.2	37.3	35.6	34.0	32.6	31.3	30.1	29.0	28.0	27.0	26.1	25.3	24.5
<b>30</b>	67.5	62.3	57.9	54.0	50.6	47.6	45.0	42.6	40.5	38.6	36.8	35.2	33.8	32.4	31.2	30.0	28.9	27.9	27.0	26.1	25.3
<b>31</b>	69.7	64.3	59.8	55.8	52.3	49.2	46.5	44.1	41.9	39.9	38.0	36.4	34.9	33.5	32.2	31.0	29.9	28.9	27.9	27.0	26.2
<b>32</b>	72.0	66.5	61.7	57.6	54.0	50.8	48.0	45.5	43.2	41.1	39.3	37.6	36.0	34.6	33.2	32.0	30.9	29.8	28.8	27.9	27.0
<b>33</b>	74.3	68.5	63.6	59.4	55.7	52.4	49.5	46.9	44.6	42.4	40.5	38.7	37.1	35.6	34.3	33.0	31.8	30.7	29.7	28.7	27.8
<b>34</b>	76.5	70.6	65.6	61.2	57.4	54.0	51.0	48.3	45.9	43.7	41.7	39.9	38.2	36.7	35.3	34.0	32.8	31.7	30.6	29.6	28.7
<b>35</b>	78.7	72.7	67.5	63.0	59.1	55.6	52.5	49.7	47.3	45.0	43.0	41.1	39.4	37.8	36.3	35.0	33.8	32.6	31.5	30.5	29.5
<b>36</b>	81.0	74.8	69.4	64.8	60.8	57.2	54.0	51.2	48.6	46.3	44.2	42.3	40.5	38.9	37.4	36.0	34.7	33.5	32.4	31.4	30.4
<b>37</b>	83.2	76.8	71.4	66.6	62.4	58.8	55.5	52.6	50.0	47.6	45.4	43.4	41.6	40.0	38.4	37.0	35.7	34.4	33.3	32.2	31.2
<b>38</b>	85.5	78.9	73.3	68.4	64.1	60.4	57.0	54.0	51.3	48.9	46.6	44.6	42.7	41.0	39.5	38.0	36.6	35.4	34.2	33.1	32.1
<b>39</b>	87.8	81.0	75.2	70.2	65.8	61.9	58.5	55.4	52.7	50.1	47.9	45.8	43.9	42.1	40.5	39.0	37.6	36.3	35.1	34.0	32.9
<b>40</b>	90.0	83.1	77.1	72.0	67.5	63.5	60.0	56.8	54.0	51.4	49.1	47.0	45.0	43.2	41.5	40.0	38.6	37.2	36.0	34.8	33.8
<b>41</b>	92.2	85.2	79.1	73.8	69.2	65.1	61.5	58.3	55.4	52.7	50.3	48.1	46.1	44.3	42.6	41.0	39.5	38.2	36.9	35.7	34.6
<b>42</b>	94.5	87.2	81.0	75.6	70.9	66.7	63.0	59.7	56.7	54.0	51.5	49.3	47.3	45.4	43.6	42.0	40.5	39.1	37.8	36.6	35.4
<b>43</b>	96.7	89.3	82.9	77.4	72.6	68.3	64.5	61.1	58.1	55.3	52.8	50.5	48.4	46.4	44.7	43.0	41.5	40.0	38.7	37.5	36.3
<b>44</b>	99.0	91.4	84.9	79.2	74.3	69.9	66.0	62.5	59.4	56.6	54.0	51.7	49.5	47.5	45.7	44.0	42.4	41.0	39.6	38.3	37.1
<b>45</b>	101.3	93.5	86.8	81.0	75.9	71.5	67.5	63.9	60.8	57.9	55.2	52.8	50.6	48.6	46.7	45.0	43.4	41.9	40.5	39.2	38.0
<b>46</b>	103.5	95.5	88.7	82.8	77.6	73.1	69.0	65.4	62.1	59.1	56.5	54.0	51.7	49.7	47.8	46.0	44.4	42.8	41.4	40.1	38.8
<b>47</b>	105.7	97.6	90.6	84.6	79.3	74.6	70.5	66.8	63.5	60.4	57.7	55.2	52.9	50.8	48.8	47.0	45.3	43.8	42.3	40.9	39.6
<b>48</b>	108.0	99.7	92.6	86.4	81.0	76.2	72.0	68.2	64.9	61.7	58.9	56.3	54.0	51.8	49.8	48.0	46.3	44.7	43.2	41.8	40.5
<b>49</b>	110.2	101.8	94.5	88.2	82.9	77.8	73.5	69.6	66.2	63.0	60.1	57.5	55.1	52.9	50.9	49.0	47.3	45.6	44.1	42.7	41.3
<b>50</b>	112.5	103.8	96.4	90.0	84.4	79.4	75.0	71.1	67.5	64.3	61.4	58.7	56.2	54.0	51.9	50.0	48.2	46.6	45.0	43.5	42.2
<b>51</b>	114.8	105.9	98.4	91.8	86.1	81.0	76.5	72.5	68.9	65.6	62.6	59.9	57.4	55.1	53.0	51.0	49.2	47.5	45.9	44.4	43.0
<b>52</b>	117.0	108.0	100.3	93.6	87.8	82.6	78.0	73.9	70.2	66.9	63.8	61.0	58.5	56.2	54.0	52.0	50.1	48.4	46.8	45.3	43.9

## YOUR TREK FRAME

- (A) Top tube
- (B) Seat tube
- (C) Down tube
- (D) Brake bridge
- (E) Seatstay
- (F) Chainstay
- (G) Dropout
- (H) Bottom bracket
- (I) Steerer tube
- (J) Head tube
- (K) Fork crown
- (L) Fork blade
- (M) Fork tip

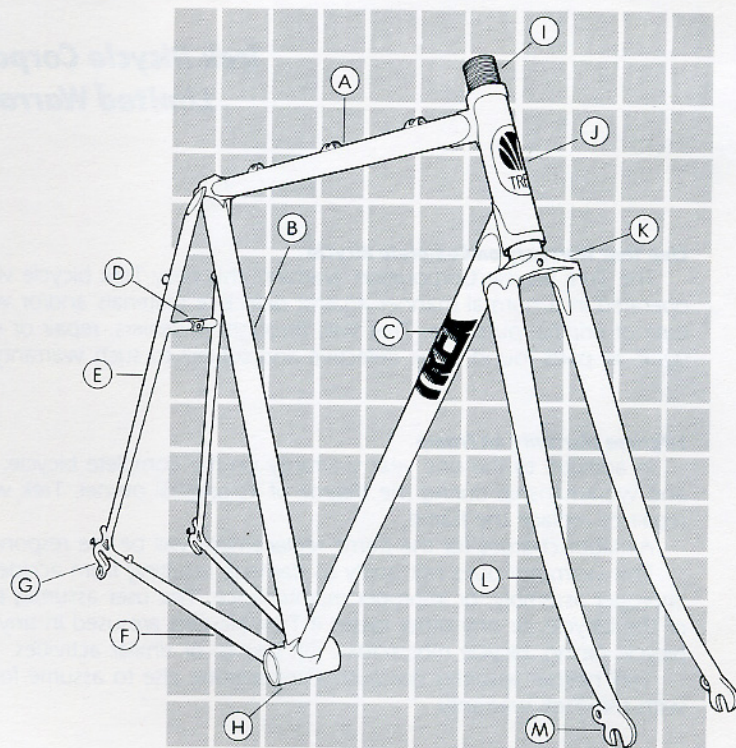



## **Trek Bicycle Corporation Limited Warranty**

### ***One Year Warranty on Complete Bicycle***

The Trek Bicycle Corporation warrants this new Trek bicycle when purchased within the United States and operated in a normal manner against defective materials and/or workmanship for a period of one year from the date of original purchase. Trek will, through its dealers, repair or replace, free of charge, including all service and labor, all parts found to be defective and subject to such warranty.

### ***Lifetime Warranty on Frame***

In addition to the one year warranty on the complete bicycle, if the frame is found to be defective in materials and workmanship during the lifetime of its original owner, Trek will, at Trek's option, through one of its dealers, repair or replace the frame.

All labor charges for the frame replacement will be the responsibility of the original owner.

This warranty does not apply to damage resulting from accident, misuse, abuse, neglect, normal wear, improper assembly, or improper maintenance. The user assumes the risk of any personal injury, damage or failure of the bicycle, or any other losses if Trek bicycles are used in any competitive event including but not limited to bicycle racing, bicycle motorcross, dirt biking, or similar activities.

Trek neither assumes nor authorizes anyone else to assume for it any other obligations or liability in connection with this Trek warranty.